

Projekt 20052994
Project

Maßzeichnung
Size drawing

15085476 (Rev.01)

Etikettiersystem
850 PF T02 P06

Logopak Systeme
Dorfstr. 40
D-24628 Hartenholm
Tel.: +49(0)4195/99750



Technische Änderungen vorbehalten! All rights reserved!

Blatt 1 / Sheet 2 Bl. Maßstab / Scale 1:20
gleibrandt 16.02.2021

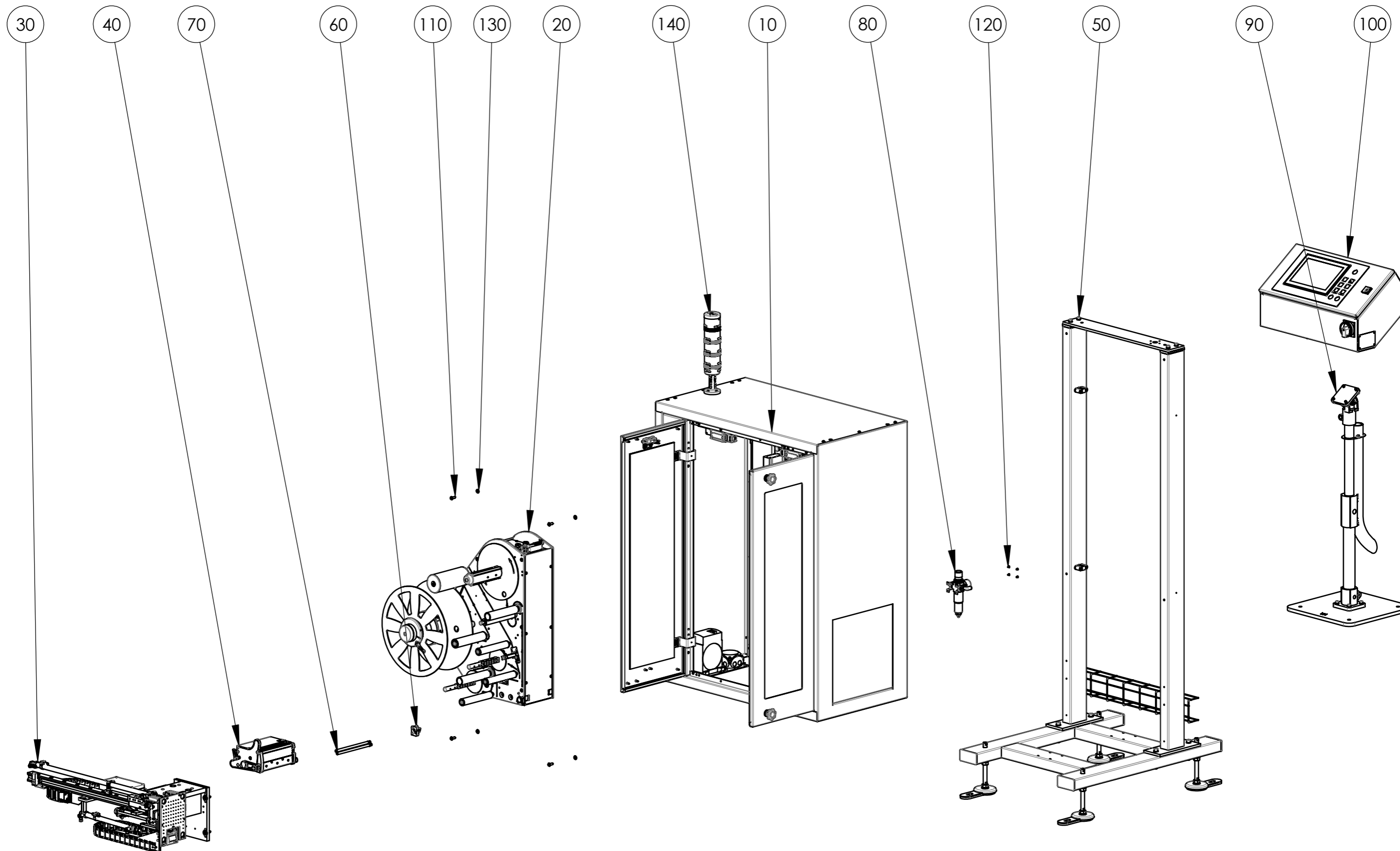

Blatt: 2/2
 20052994 Format: A3
 Etikettiersystem Maßstab 1:16
 15085476 (Rev.01) Datum: 16.02.2021

Logopak Systeme
 GmbH & Co. KG
 Dorfstraße 40
 D-24628 Hartenholm

